

CHECK VALVE APPLICATION

Sometimes referred to as non-return valve, check valves prevent back-flow, constantly keeping flow in one direction. Check valves are designed to close quickly and automatically with positive shut off in either horizontal or vertical (flow up) pipe runs. Inherently, swing check valves have a low pressure drop and are best suitable for velocity applications. Our enclosure design allows check valve to close completely and remain closed even with no flow when installed in a pipe run.

MANUFACTURING STANDARDS

General Design	BS1868 / API 6D / API 600 / API 603
Face To Face	ASME/ANSI B16.10
Flange End	ASME/ANSI B16.5 & B16.47
Butt Weld End	ASME/ANSI B16.25
Fire Safe Design	API 6FA
Pressure Rating	ASME/ANSI B16.34
Inspection & Test	API 598 / API 6D
Features	Bolted Cap, Swing Disc

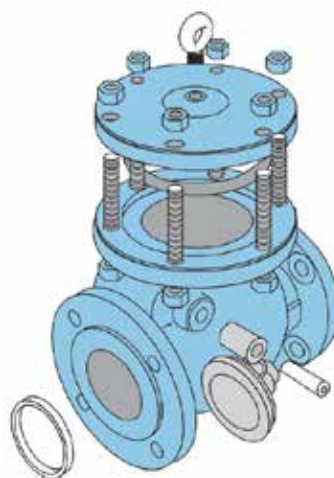

DISC

Each disc's seating surface is precision ground and paired to the seat ring for a positive shut off. The disc is secured to the hinge arm with the disc nut and pinned to prevent disengagement during service.

SEAT RING

Seat rings are designed to greatly reduce and / or prevent any turbulence and to avoid damage due to the corrosion. Seat rings for check valves are typically made from forged steel.

END CONNECTIONS

Our valve standard end connections are available in:

- Flange end type with Raised Face (RF), Flat Face (FF) or Ring Type Joint (RTJ) that conform to ANSI B16.5.
- Butt-welding ends (BW) that conform to ANSI B16.25.
- Threaded ends (NPT) that conform to ANSI B1.20.1 socket weld ends (SW) that conform to ANSI B16.11.
- All face-to-face / end-to-end dimensions conform to ANSI B16.10.

Other special end connections can be supplied according to customer's requirements.

CAST STEEL SWING CHECK

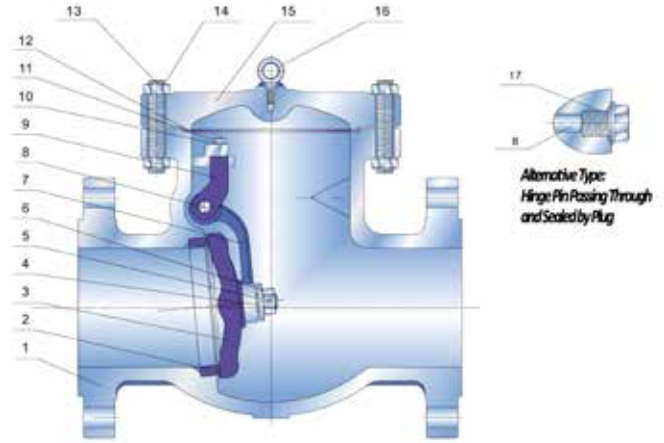

STANDARD PARTS & MATERIAL

No.	Parts	CARBON STEEL		ALLOY STEEL				STAINLESS STEEL	
		WCB	LCB	WC6	WC9	C5	C12	CF8(M)	CF3(M)
1	Body	A216 WCB	A352 LCB	A217 WC6	A217 WC9	A217 C5	A217 C12	A351 CF8(M)	A351 CF3(M)
2	Seat	A105 + STL	A350 LF2 + STL	A182 F11 + STL	A182 F22 + STL	A182 F5 + STL	A182 F9 + STL	A351 CF8(M)	A351 CF3(M)
3	Disc	A216 WCB + 13CR	A352 LCB + 13CR	A217 WC6 + 13CR	A217 WC9 + 13CR	A217 C5 + 13CR	A217 C12 + 13CR	A351 CF8(M)	A351 CF3(M)
4	Disc Washer	A276 410	A276 304	A276 410				A276 316	
5	Disc Nut Pin	Steel						SS316	
6	Disc Nut	Steel						SS316	
7	Hinge	A216 WCB	A352 LCB	A217 WC6	A217 WC9	A217 C5	A217 C12	A351 CF8(M)	A351 CF3(M)
8	Hinge Pin	A182 F6a	A182 F304	A182 F6a				A182 F304/F316	
9	Bearing Bracket	A216 WCB	A352 LCB	A217 WC6	A217 WC9	A217 C5	A217 C12	A351 CF8(M)	A351 CF3(M)
10	Spring Washer	Carbon Steel	Steel				SS316		
11	Hex, Bolt	A193 B7	A320 L7	A193 B16				A193 B8	
12	Gasket	SS304 + Graphite						PTFE / SS316 + Graphite	
13	Cover Bolt	A193 B7	A320 L7	A193 B16				A193 B8	
14	Cover Bolt Nut	A194 2H	A194 4				A194 8		
15	Cover	A216 WCB	A352 LCB	A217 WC6	A217 WC9	A217 C5	A217 C12	A351 CF8(M)	A351 CF3(M)
16	Eye Bolt	Carbon Steel	Steel				SS316		
17	Plug	A105	A350 LF2	A182 F11	A182 F22	A182 F5	A182 F9	A182 F304/F316	A182 F304L/F316L

Other valve material composition are available.

CAST STEEL SWING CHECK

CLASS 150 API 600 / ASME B16.34

Size (in)	L (RF)	L1 (BW)	L2 (RTJ)	H	Wt. (Kg)
2	203 (8.00)	203 (8.00)	216 (8.50)	151 (5.90)	15
2.1/2	216 (8.50)	216 (8.50)	229 (9.00)	168 (6.60)	22
3	241 (9.50)	241 (9.50)	254 (10.00)	171 (6.70)	28
4	292 (11.50)	292 (11.50)	305 (12.00)	204 (8.00)	42
5	330 (13.00)	330 (13.00)	343 (13.50)	230 (9.10)	57
6	356 (14.00)	356 (14.00)	368 (14.50)	297 (11.70)	79
8	495 (19.50)	495 (19.50)	508 (20.00)	352 (13.80)	131
10	622 (24.50)	622 (24.50)	635 (25.00)	390 (15.30)	177
12	699 (27.50)	699 (27.50)	711 (28.00)	438 (17.20)	282
14	787 (31.00)	787 (31.00)	800 (31.50)	477 (18.80)	380
16	864 (34.00)	864 (34.00)	876 (34.50)	525 (20.70)	542
18	978 (38.50)	978 (38.50)	991 (39.00)	582 (22.90)	632
20	978 (38.50)	978 (38.50)	991 (39.00)	627 (24.70)	855
24	1295 (51.00)	1295 (51.00)	1308 (21.50)	880 (34.60)	970
26	1295 (51.00)	1295 (51.00)	-	910 (35.80)	1276
28	1448 (57.00)	1448 (57.00)	-	935 (36.80)	1600
30	1524 (60.00)	1524 (60.00)	-	970 (38.20)	2020
32	1727 (68.00)	1727 (68.00)	-	1250 (49.20)	2430
36	1956 (77.00)	1956 (77.00)	-	1377 (54.20)	3130
40	2159 (85.00)	2159 (85.00)	-	1410 (55.50)	4230
42	2261 (89.00)	2261 (89.00)	-	1468 (57.80)	5030
48	2566 (101.00)	2566 (101.00)	-	1642 (64.60)	6680

Standard Fig. No. 3A1C1

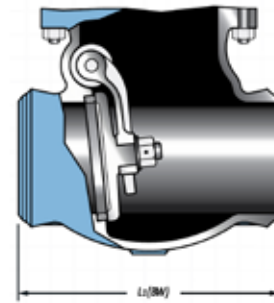
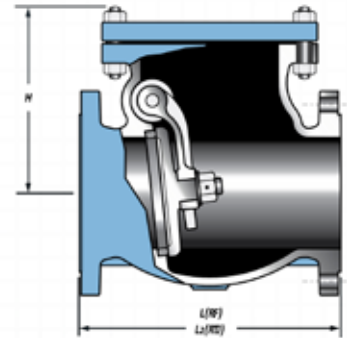

CLASS 300 API 600 / ASME B16.34

Size (in)	L (RF)	L1 (BW)	L2 (RTJ)	H	Wt. (Kg)
2	267 (10.50)	267 (10.50)	283 (11.12)	176 (6.90)	16
2.1/2	292 (11.50)	292 (11.50)	308 (12.12)	185 (7.30)	22
3	318 (12.50)	318 (12.50)	333 (13.12)	216 (8.50)	30
4	356 (14.00)	356 (14.00)	371 (14.62)	259 (10.20)	53
5	400 (15.75)	400 (15.75)	416 (16.38)	304 (12.00)	73
6	445 (17.50)	445 (17.50)	460 (18.12)	317 (12.50)	101
8	533 (21.00)	533 (21.00)	549 (21.62)	380 (15.00)	157
10	622 (24.50)	622 (24.50)	638 (25.12)	434 (17.10)	232
12	711 (28.00)	711 (28.00)	727 (28.62)	511 (20.10)	414
14	838 (33.00)	838 (33.00)	854 (33.62)	561 (22.10)	455
16	864 (34.00)	864 (34.00)	879 (34.62)	596 (23.50)	766
18	978 (38.50)	978 (38.50)	994 (39.12)	675 (26.60)	774
20	1016 (40.00)	1016 (40.00)	1035 (40.75)	730 (28.70)	960
24	1346 (53.00)	1346 (53.00)	1368 (53.88)	860 (33.90)	1792
26	1346 (53.00)	1346 (53.00)	-	930 (36.60)	1995
28	1499 (59.00)	1499 (59.00)	-	1163 (45.80)	2260
30	1594 (62.75)	1594 (62.75)	-	1270 (50.00)	2780
32	1727 (68.00)	1727 (68.00)	-	1270 (50.00)	3380
36	2083 (82.00)	2083 (82.00)	-	1510 (59.40)	5030

Standard Fig. No. 3A1C3

Unit : mm (inch)

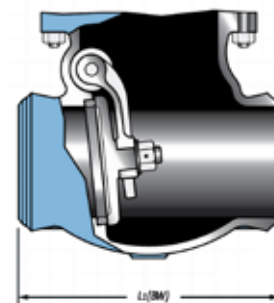
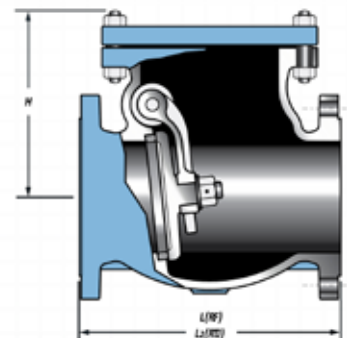

CAST STEEL SWING CHECK

CLASS 600 API 600 / ASME B16.34

Size (In)	L (RF)	L1 (BW)	L2 (RTJ)	H	Wt. (Kg)
2	292 (11.50)	292 (11.50)	295 (11.62)	184 (7.20)	30
2.1/2	330 (13.00)	330 (13.00)	333 (13.12)	210 (8.30)	43
3	356 (14.00)	356 (14.00)	359 (14.12)	232 (9.10)	55
4	432 (17.00)	432 (17.00)	435 (17.12)	263 (10.40)	93
5	508 (20.00)	508 (20.00)	511 (20.12)	295 (11.60)	160
6	559 (22.00)	559 (22.00)	562 (22.12)	374 (14.70)	208
8	660 (26.00)	660 (26.00)	664 (26.12)	426 (16.80)	339
10	787 (31.00)	787 (31.00)	791 (31.12)	517 (20.40)	547
12	838 (33.00)	838 (33.00)	841 (33.12)	569 (22.40)	715
14	889 (35.00)	889 (35.00)	892 (35.12)	622 (24.50)	885
16	991 (39.00)	991 (39.00)	994 (39.12)	680 (26.80)	1310
18	1092 (43.00)	1092 (43.00)	1095 (43.12)	752 (29.80)	1620
20	1194 (47.00)	1194 (47.00)	1200 (47.25)	975 (38.40)	2120
24	1397 (55.00)	1397 (55.00)	1407 (55.38)	1111 (43.70)	3100
26	1448 (57.00)	1448 (57.00)	-	1111 (43.70)	3800
28	1600 (63.00)	1600 (63.00)	-	1192 (46.90)	4600
30	1651 (65.00)	1651 (65.00)	-	1324 (52.10)	5500
32	1778 (70.00)	1778 (70.00)	-	1367 (53.80)	6800
36	2083 (82.00)	2083 (82.00)	-	1542 (60.70)	8100

Standard Fig. No. 3A1C6

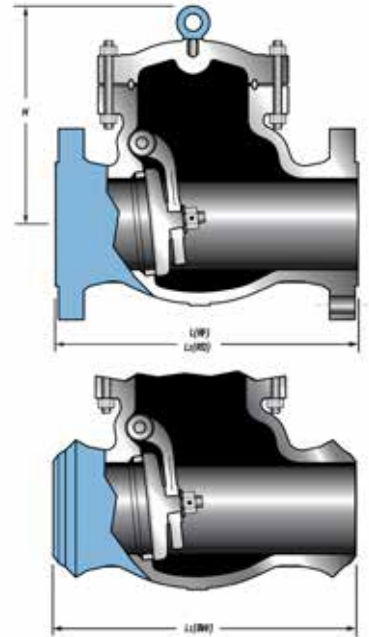

CLASS 900 API 600 / ASME B16.34

Size (In)	L (RF)	L1 (BW)	L2 (RTJ)	H	Wt. (Kg)
2	368 (14.50)	368 (14.50)	371 (14.62)	296 (11.70)	70
2.1/2	419 (16.50)	419 (16.50)	422 (16.62)	300 (11.80)	100
3	381 (15.00)	381 (15.00)	384 (15.12)	300 (11.80)	110
4	457 (18.00)	457 (18.00)	460 (18.12)	327 (12.90)	150
6	610 (24.00)	610 (24.00)	613 (24.12)	441 (17.40)	305
8	737 (29.00)	737 (29.00)	740 (29.12)	502 (19.80)	510
10	838 (33.00)	838 (33.00)	841 (33.12)	664 (26.10)	810
12	965 (38.00)	965 (38.00)	968 (38.12)	775 (30.50)	1120
14	1029 (40.50)	1029 (40.50)	1038 (40.38)	782 (30.80)	1380
16	1130 (44.50)	1130 (44.50)	1140 (44.88)	838 (33.00)	1900
18	1219 (48.00)	1219 (48.00)	1095 (43.11)	839 (33.00)	3000
20	1321 (52.00)	1321 (52.00)	1200 (47.24)	932 (36.70)	4000
24	1549 (61.00)	1549 (61.00)	1407 (55.39)	924 (36.40)	5200

Standard Fig. No. 3A1C9

Unit : mm (inch)

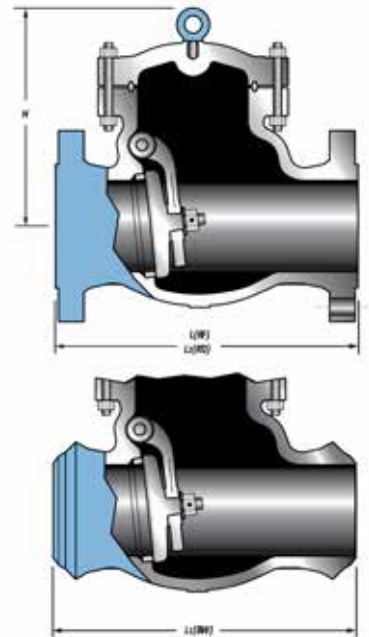

CAST STEEL SWING CHECK

CLASS 1500 API 600 / ASME B16.34	Size (in)	L (RF)	L1 (BW)	L2 (RTJ)	H	Wt. (Kg)
	2	368 (14.50)	368 (14.50)	371 (14.61)	296 (11.70)	70
	2.1/2	419 (16.50)	419 (16.50)	422 (16.61)	300 (11.80)	100
	3	470 (18.50)	470 (18.50)	473 (18.62)	341 (13.40)	150
	4	546 (21.50)	546 (21.50)	549 (21.61)	412 (16.20)	245
	6	705 (27.75)	705 (27.75)	711 (28.00)	511 (20.10)	550
	8	832 (32.75)	832 (32.75)	841 (33.11)	680 (26.80)	1010
	10	991 (39.00)	991 (39.00)	1000 (39.37)	756 (29.80)	1476
	12	1130 (44.50)	1130 (44.50)	1146 (45.12)	857 (33.70)	2280
	14	1257 (49.50)	1257 (49.50)	1276 (50.24)	950 (37.40)	3060
16	1384 (54.50)	1384 (54.50)	1407 (55.39)	1020 (40.10)	4500	

Standard Fig. No. 3A1C15

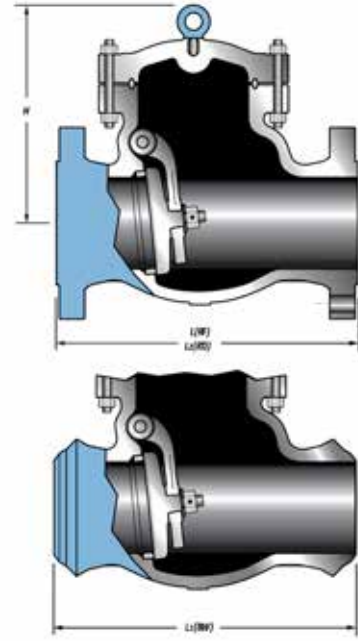

CLASS 2500 API 600 / ASME B16.34	Size (in)	L (RF)	L1 (BW)	L2 (RTJ)	H	Wt. (Kg)
	2	451 (17.75)	451 (17.75)	454 (17.91)	416 (16.40)	145
	2.1/2	508 (20.00)	508 (20.00)	514 (20.24)	419 (16.50)	240
	3	578 (22.75)	578 (22.75)	584 (23.00)	441 (17.40)	330
	4	673 (26.50)	673 (26.50)	683 (26.89)	479 (18.90)	650
	6	914 (36.00)	914 (36.00)	927 (36.50)	511 (20.10)	806
	8	1022 (40.25)	1022 (40.25)	1038 (40.87)	711 (28.00)	2420
	10	1270 (50.00)	1270 (50.00)	1292 (50.87)	851 (33.50)	3750
12	1422 (56.00)	1422 (56.00)	1445 (56.89)	1000 (39.40)	5500	

Standard Fig. No. 3A1C25

Unit : mm (inch)

FORGED STEEL LIFT CHECK

BOLTED / WELDED CAP - REDUCED / FULL PORT

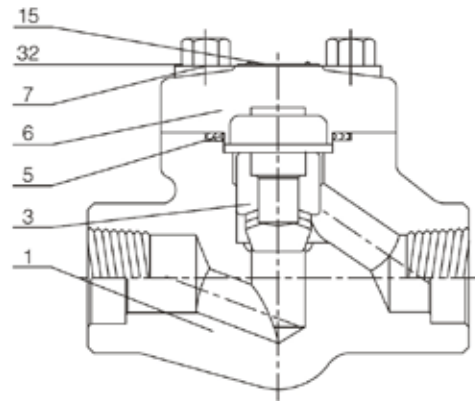

Please mark in you need load spring

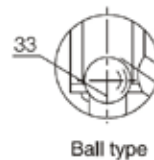

Ball type

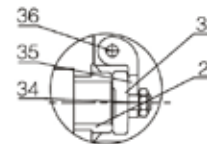

Swing type

STANDARD PARTS & MATERIAL

No.	Parts	A105/N	LF2	F11	F22	F304/L	F316/L	F51	
1	Body	A105/N	A350-LF2	A182-F11	A182-F22	A182-F304/L	A182-F316/L	A182-F51	
2	Seat	410+STL	304+STL	410+STL	410+STL	304+STL	316+STL	F51+STL	
3	Disc	410	304	420	420	304	316	F51	
5	Gasket	Flexible Graphite + SS Wire							
6	Cap	A105/N	A350-LF2	A182-F11	A182-F22	A182-F304/L	A182-F316/L	A182-F51	
7	Cap Bolt	A193-B7	A193-L7	A193-B16		A193-B8	A193-B8(M)		
15	Name Plate	Aluminium							
32	Rivet	T3							
33	Ball	410	304	410		304/L	316/L	F51	
34	Disc Nut	A194-8					A194-8(M)		
35	Hinge	A351-CF8					A351-CF8M		
36	Pin	304					316		

Other valve material composition are available.

FORGED STEEL LIFT CHECK

MANUFACTURING STANDARD

General Design	API 602
Face To Face	ASME/ANSI B16.10
Connection	Screw NPT to ANSI B1.20.1, Socket Weld to ANSI B16.11, Buttweld to ANSI B16.25
Fire Safe Design	API 6FA
Pressure Rating	ASME/ANSI B16.34
Inspection & Test	API 598 / API 6D
Features	Bolted Cap / Welded Cap, Piston, Spring Loaded (Optional)

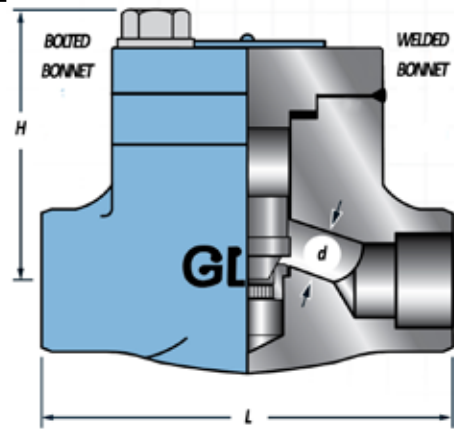

CLASS 800 - API 602	Port	Size (In)	L	H	d	Wt. (Kg)
	REGULAR	1/4	79 (3.11)	54.5 (2.15)	6.5 (0.26)	2
		1/2	79 (3.11)	54.5 (2.15)	10.0 (0.39)	2
		3/4	92 (3.62)	54.5 (2.15)	13.0 (0.51)	2
		1	111 (4.37)	72.0 (2.83)	17.5 (0.69)	3
		1.1/4	120 (4.72)	81.0 (3.19)	23.0 (0.91)	4
		1.1/2	152 (5.98)	94.0 (3.70)	28.5 (1.12)	5
	FULL	2	172 (6.77)	112.0 (4.41)	35.0 (1.38)	9
		1/2	92 (3.62)	54.5 (2.15)	13.0 (0.51)	2
		3/4	111 (4.37)	72.0 (2.83)	17.5 (0.69)	3
1		120 (4.72)	81.0 (3.19)	23.0 (0.91)	4	
	1.1/4	152 (5.98)	94.0 (3.70)	28.5 (1.12)	5	
	1.1/2	172 (6.77)	112.0 (4.41)	35.0 (1.38)	9	
	2	220 (8.66)	132.0 (5.20)	47.0 (1.85)	16	

Standard Fig. No. 3A2F8

CLASS 1500 - API 602	Port	Size (In)	L	H	d	Wt. (Kg)
	REGULAR	1/4	79 (3.11)	54.5 (2.15)	6.5 (0.26)	2
		1/2	92 (3.62)	54.5 (2.15)	10.0 (0.39)	2
		3/4	111 (4.37)	54.5 (2.15)	13.0 (0.51)	2
		1	120 (4.72)	72.0 (2.83)	17.5 (0.69)	3
		1.1/4	152 (5.98)	81.0 (3.19)	23.0 (0.91)	4
		1.1/2	172 (6.77)	94.0 (3.70)	28.5 (1.12)	5
	FULL	2	220 (8.66)	112.0 (4.41)	35.0 (1.38)	9
		1/2	111 (4.37)	73.0 (2.87)	13.0 (0.51)	3
		3/4	120 (4.72)	84.0 (3.31)	17.5 (0.69)	5
1		152 (5.98)	97.0 (3.82)	23.0 (0.91)	7	
	1.1/4	172 (6.77)	115.0 (4.53)	28.5 (1.12)	11	
	1.1/2	220 (8.66)	132.0 (5.20)	35.0 (1.38)	16	
	2	250 (9.84)	132.0 (5.20)	47.0 (1.85)	17	

Standard Fig. No. 3A2F15

CLASS 2500 - API 602	Port	Size (In)	L	H	d	Wt. (Kg)
	REGULAR	1/2	150 (5.90)	135 (5.31)	11.0 (0.43)	7
		3/4	150 (5.90)	135 (5.31)	17.0 (0.66)	7
		1	170 (6.70)	146 (5.74)	19.0 (0.74)	11
		1.1/4	200 (7.87)	176 (6.92)	25.0 (0.98)	18
		1.1/2	200 (7.87)	176 (6.92)	28.0 (1.10)	18
		2	250 (9.84)	196 (7.71)	35.0 (1.38)	29

Standard Fig. No. 3A2F25

Unit : mm (inch)

FORGED STEEL SWING CHECK

MANUFACTURING STANDARD

General Design	API 602
Face To Face	ASME/ANSI B16.10
Connection	Screw NPT to ANSI B1.20.1, Socket Weld to ANSI B16.11, Buttweld to ANSI B16.25
Fire Safe Design	API 6FA
Pressure Rating	ASME/ANSI B16.34
Inspection & Test	API 598 / API 6D
Features	Bolted Cap / Welded Cap, Swing type

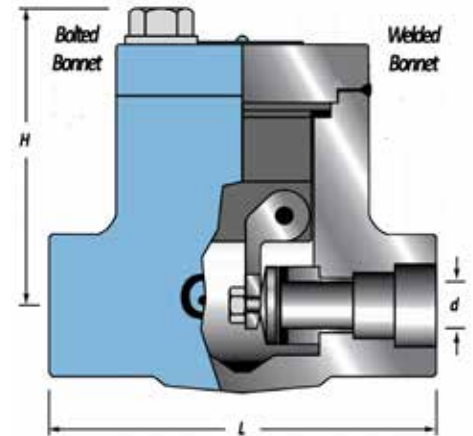

CLASS 800- API 602	Port	Size (In)	L	H	d	Wt. (Kg)
	REGULAR	1/4	79 (3.11)	54.5 (2.15)	8.0 (0.31)	1
		1/2	79 (3.11)	54.5 (2.15)	13.0 (0.51)	1
		3/4	92 (3.62)	54.5 (2.15)	13.0 (0.51)	2
		1	111 (4.37)	72.0 (2.83)	18.0 (0.69)	2
		1.1/4	120 (4.72)	81.0 (3.19)	24.0 (0.94)	4
		1.1/2	120 (4.72)	94.0 (3.70)	29.0 (1.12)	5
	FULL	2	140 (5.51)	112.0 (4.41)	36.8 (1.45)	9
		1/2	92 (3.62)	54.5 (2.15)	13.0 (0.51)	2
		3/4	111 (4.37)	72.0 (2.83)	18.0 (0.69)	2
		1	120 (4.72)	81.0 (3.19)	24.0 (0.94)	4
		1.1/4	120 (4.72)	94.0 (3.70)	29.0 (1.12)	5
1.1/2		140 (5.51)	112.0 (4.41)	36.8 (1.45)	9	
2	160 (6.30)	132.0 (5.20)	48.0 (1.89)	15		

Standard Fig. No. 3A2F8

CLASS 1500 - API 602	Port	Size (In)	L	H	d	Wt. (Kg)
	REGULAR	1/4	79 (3.11)	73 (2.87)	6.8 (0.26)	2
		1/2	92 (3.62)	73 (2.87)	13.0 (0.51)	2
		3/4	111 (4.37)	73 (2.87)	13.0 (0.51)	3
		1	120 (4.72)	84 (3.31)	18.0 (0.69)	4
		1.1/4	120 (4.72)	97 (3.82)	24.0 (0.94)	6
		1.1/2	140 (5.51)	115 (4.53)	29.0 (1.12)	10
		2	160 (6.30)	132 (5.20)	36.8 (1.45)	15
	FULL	1/2	111 (4.37)	73 (2.87)	13.0 (0.51)	3
		3/4	120 (4.72)	84 (3.31)	18.0 (0.69)	4
		1	120 (4.72)	97 (3.82)	24.0 (0.94)	6
		1.1/4	140 (5.51)	115 (4.53)	29.0 (1.12)	10
		1.1/2	160 (6.30)	132 (5.20)	36.8 (1.45)	15
		2	220 (8.66)	132 (5.20)	48.0 (1.89)	17

Standard Fig. No. 3A2F15

Unit : mm (inch)

FORGED STEEL CHECK VALVE

MANUFACTURING STANDARD

General Design	API 602
Face To Face	ASME/ANSI B16.10
Connection	Flange to ANSI B16.5
Fire Safe Design	API 6FA
Pressure Rating	ASME/ANSI B16.34
Inspection & Test	API 598 / API 6D
Features	Bolted Cap / Welded Cap, Piston & Swing type, Spring Loaded (Optional)

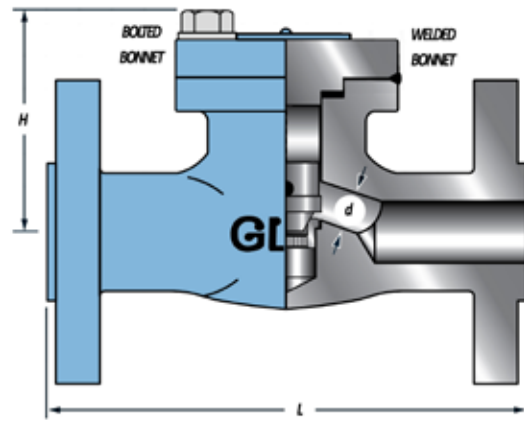

CLASS 150 API 602	Size (in)	L	H	d (Lift)	d (Swing)	Wt. (Kg)
	1/2	108 (4.25)	54.5 (2.15)	10.0 (0.39)	13.0 (0.51)	3
	3/4	117 (4.61)	54.5 (2.15)	13.0 (0.51)	13.0 (0.51)	4
	1	127 (5.00)	72.0 (2.83)	17.5 (0.69)	18.0 (0.69)	8
	1.1/4	140 (5.50)	81.0 (3.19)	23.0 (0.91)	24.0 (0.94)	9
	1.1/2	165 (6.50)	91.0 (3.58)	28.5 (1.12)	29.0 (1.12)	12
	2	203 (7.99)	112.0 (4.41)	35.0 (1.38)	36.8 (1.45)	14

Standard Fig. No. 3A2F1

CLASS 300 API 602	Size (in)	L	H	d (Lift)	d (Swing)	Wt. (Kg)
	1/2	152 (5.98)	54.5 (2.15)	10.0 (0.39)	13.0 (0.51)	4
	3/4	178 (7.01)	54.5 (2.15)	13.0 (0.51)	13.0 (0.51)	5
	1	216 (8.50)	72.0 (2.83)	17.5 (0.69)	18.0 (0.69)	9
	1.1/4	229 (9.02)	81.0 (3.19)	23.0 (0.91)	24.0 (0.94)	10
	1.1/2	241 (9.49)	91.0 (3.58)	28.5 (1.12)	29.0 (1.12)	14
	2	267 (10.51)	112.0 (4.41)	35.0 (1.38)	36.8 (1.45)	18

Standard Fig. No. 3A2F3

CLASS 600 API 602	Size (in)	L	H	d (Lift)	d (Swing)	Wt. (Kg)
	1/2	165 (6.50)	54.5 (2.15)	10.0 (0.39)	13.0 (0.51)	4
	3/4	190 (7.50)	54.5 (2.15)	13.0 (0.51)	13.0 (0.51)	6
	1	216 (8.50)	72.0 (2.83)	17.5 (0.69)	18.0 (0.69)	10
	1.1/4	229 (9.02)	81.0 (3.19)	23.0 (0.91)	24.0 (0.94)	10
	1.1/2	241 (9.49)	91.0 (3.58)	28.5 (1.12)	29.0 (1.12)	16
	2	292 (11.50)	112.0 (4.41)	35.0 (1.38)	36.8 (1.45)	25

Standard Fig. No. 3A2F6

CLASS 1500 API 602	Size	L	H	d (Lift)	d (Swing)	Wt. (Kg)
	1/2	216 (8.50)	73 (2.87)	10.0 (0.39)	13.0 (0.51)	9
	3/4	229 (9.02)	73 (2.87)	13.0 (0.51)	13.0 (0.51)	11
	1	254 (10.00)	84 (3.31)	17.5 (0.69)	18.0 (0.69)	14
	1.1/4	279 (10.98)	97 (3.82)	23.0 (0.91)	24.0 (0.94)	16
	1.1/2	305 (12.01)	115 (4.53)	28.5 (1.12)	29.0 (1.12)	22
	2	368 (14.49)	132 (5.20)	35.0 (1.38)	36.8 (1.45)	28

Standard Fig. No. 3A2F15

Unit : mm (inch)

CAST STEEL WAFER CHECK

DUAL PLATE WAFER CHECK VALVE

Dual plate wafer check valve is typically installed in support of automatic shutdown valves and safety devices. Its purpose is to prevent and protect devices against the consequences of unintended reverse flow. It is immediately responsive and fast acting in its closure, thereby maximising protection to prevent or minimize the adverse effect of any backflow. It is not an isolating valve and should not be used as such. GLT dual plate wafer check valve provides enhance protection for the safety of equipment, plant, and against the loss of production. It is widely applied in the petroleum, petro-chemical, LNG, and other industries.

MANUFACTURING STANDARDS

General Design	API 6D / API 594
Fire Safe Design	API 607 / API 6FA
Pressure Rating	ASME / ANSI B16.34
Face to Face	ASME / ANSI B 16.10
Flange dimensions	ASME / ANSI B 16.5, ANSI 16.47A & ANSI B16.47B
Test & Inspection	API 6D / API 598

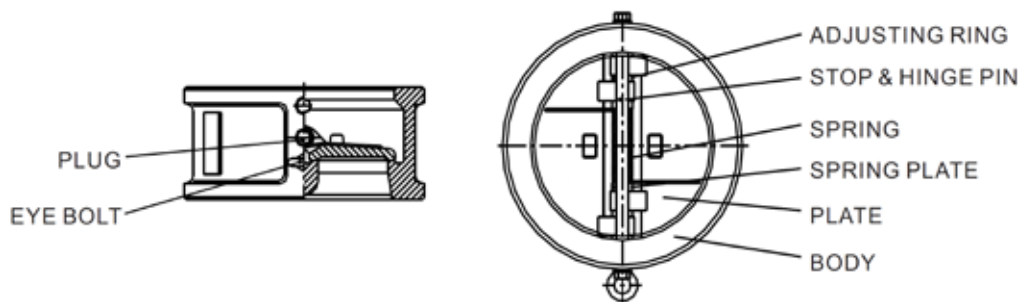

STANDARD PARTS & MATERIAL

No	Parts	CARBON STEEL			LOW CARBON STEEL		STAINLESS STEEL			
		13CR TRIM	SS304 TRIM	SS316 TRIM	SS304 TRIM	SS316 TRIM	SS304	SS316	SS304L	SS316L
1	Body	A216 WCB	A216 WCB	A216 WCB	A352 LCB	A352 LCB	A351 CF8	A351 CF8M	A351 CF3	A351 CF3M
2	Seat	NBR / VITON / 13CR / STELLITE / SS304 / SS316								
3	Plate	A217 CA15	A351 CF8	A351 CF8M	A351 CF8	A351 CF8M	A351 CF8	A351 CF8M	A351 CF3	A351 CF3M
4	Hinge Pin	A182 F6	A182 F304	A182 F316	A182 F304	A182 F316	A182 F304	A182 F316	A182 F304L	A182 F316L
5	Retainer Pin	A182 F6	A182 F304	A182 F316	A182 F304	A182 F316	A182 F304	A182 F316	A182 F304L	A182 F316L
6	Spring	INCONEL X750								
7	Eye Bolt	AISI 1035								
8	Bearing	PTFE / 13CR / SS304 / SS316								
9	Plug	STEEL								

Other valve material composition are available.

CAST STEEL WAFER CHECK

CLASS 150 - API 594

Size (In)	A	B	C	STUD SELECTION (In)			Wt. (Kg)
				No.	Dia.	Length	
2	105 (4.13)	60 (2.36)	57 (2.24)	4	0.625	6.000	3
2.1/2	124 (4.88)	67 (2.63)	77 (3.03)	4	0.625	6.375	5
3	137 (5.39)	73 (2.87)	90 (3.54)	4	0.625	7.000	6
4	175 (6.89)	73 (2.87)	110 (4.33)	8	0.615	7.000	8
5	191 (7.52)	86 (3.39)	141 (5.55)	8	0.750	7.375	12
6	222 (8.74)	98 (3.89)	166 (6.54)	8	0.750	8.250	16
8	279 (10.98)	127 (5.00)	206 (8.11)	8	0.750	9.750	21
10	340 (13.39)	146 (5.75)	260 (10.24)	12	0.875	11.000	48
12	410 (16.14)	181 (7.13)	300 (11.81)	12	0.875	12.250	78
14	451 (17.76)	184 (7.24)	348 (13.70)	12	1.000	13.000	91
16	514 (20.24)	191 (7.52)	388 (15.28)	16	1.000	13.500	125
18	549 (21.61)	203 (7.99)	438 (17.24)	16	1.125	14.500	143
20	606 (23.86)	219 (8.62)	486 (19.13)	20	1.250	15.125	197
24	718 (28.27)	222 (8.74)	580 (22.83)	20	1.250	16.250	281

Standard Fig. No. 4A1C1

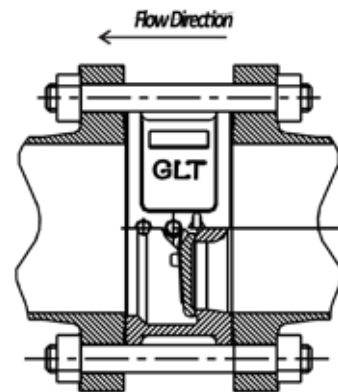
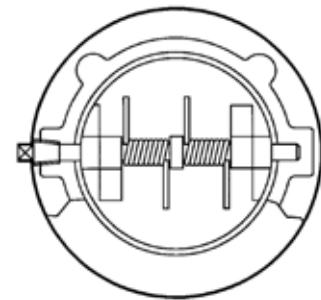
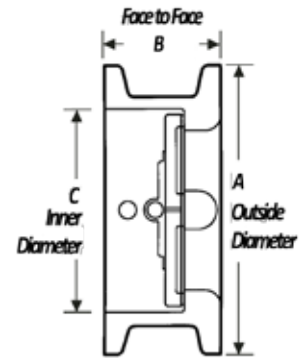

CLASS 300 - API 594

Size (In)	A	B	C	STUD SELECTION (In)			Wt. (Kg)
				No.	Dia.	Length	
2	111 (4.37)	60 (2.36)	57 (2.24)	8	0.625	6.875	3
2.1/2	130 (5.12)	67 (2.63)	77 (3.03)	8	0.750	6.875	5
3	149 (5.87)	73 (2.87)	90 (3.54)	8	0.75	8.125	6
4	181 (7.13)	73 (2.87)	110 (4.33)	8	0.750	8.125	8
5	216 (8.50)	86 (3.39)	141 (5.55)	8	0.750	8.125	16
6	251 (9.88)	98 (3.89)	166 (6.54)	12	0.570	9.625	20
8	308 (12.13)	127 (5.00)	206 (8.11)	12	0.875	14.500	37
10	362 (14.25)	146 (5.75)	260 (10.24)	12	1.000	12.750	57
12	422 (16.61)	181 (7.13)	300 (11.81)	16	1.125	14.625	91
14	486 (19.13)	222 (8.74)	348 (13.70)	20	1.125	16.500	147
16	540 (21.26)	232 (9.14)	388 (15.28)	20	1.250	17.375	188
18	597 (23.50)	264 (10.39)	438 (17.24)	24	1.250	18.875	252
20	654 (25.75)	292 (11.50)	486 (19.13)	24	1.250	20.500	329
24	775 (30.51)	318 (12.51)	580 (22.83)	24	1.500	22.750	499

Standard Fig. No. 4A1C3

CLASS 600 - API 594

Size (In)	A	B	C	STUD SELECTION (In)			Wt. (Kg)
				No.	Dia.	Length	
2	111 (4.37)	60 (2.36)	57 (2.24)	8	0.625	6.875	3
3	149 (5.87)	73 (2.87)	90 (3.54)	8	0.750	8.125	7
4	194 (7.64)	73 (2.87)	110 (4.33)	8	0.875	9.500	12
6	267 (10.51)	136 (5.35)	166 (6.54)	12	1.000	12.375	36
8	321 (12.63)	165 (6.50)	206 (8.11)	12	1.125	14.500	61
10	400 (10.16)	213 (8.39)	260 (10.24)	16	1.250	17.125	108
12	457 (17.99)	229 (9.02)	300 (11.81)	20	1.250	18.000	151
14	492 (19.37)	273 (10.75)	348 (13.70)	20	1.375	20.250	206
16	565 (22.24)	305 (12.00)	388 (15.28)	20	1.500	22.250	290
18	613 (24.13)	362 (14.25)	438 (17.24)	20	1.625	25.250	404
20	683 (26.89)	368 (14.49)	486 (19.13)	24	1.625	26.250	508
24	791 (31.14)	438 (17.24)	588 (23.15)	24	1.875	30.750	925

Standard Fig. No. 4A1C6

Unit : mm (inch)

CAST STEEL WAFER CHECK

CLASS 900 API 594	Size (In)	A	B	C	STUD SELECTION (In)			Wt. (Kg)
					No.	Dia.	Length	
3	168 (5.63)	83 (3.26)	90 (3.54)	8	0.875	9.500	11	
4	206 (8.11)	102 (4.02)	110 (4.33)	8	1.125	11.000	18	
6	289 (11.38)	159 (6.25)	166 (6.54)	12	1.125	14.000	52	
8	359 (14.14)	206 (8.11)	206 (8.11)	12	1.375	17.125	104	
10	435 (17.13)	241 (9.49)	260 (10.24)	16	1.375	19.000	176	
12	498 (19.61)	292 (11.50)	300 (11.81)	20	1.375	21.750	245	
14	541 (21.30)	356 (14.02)	348 (13.70)	20	1.500	25.500	420	
16	575 (22.64)	384 (15.12)	388 (15.28)	20	1.625	27.125	523	

Standard Fig. No. 4A1C9

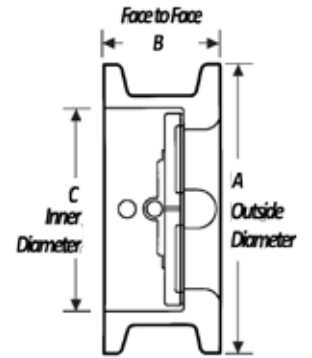

CLASS 1500 API 594	Size (In)	A	B	C	STUD SELECTION (In)			Wt. (Kg)
					No.	Dia.	Length	
3	175 (6.89)	83 (3.26)	90 (3.54)	8	1.125	10.500	11	
4	210 (8.26)	102 (4.02)	110 (4.33)	8	1.250	12.000	20	
6	283 (11.14)	159 (6.25)	166 (6.54)	12	1.375	16.750	50	
8	352 (13.86)	206 (8.11)	206 (8.11)	12	1.625	20.25	99	
10	435 (17.13)	248 (9.76)	260 (10.24)	12	1.875	23.500	180	
12	421 (16.57)	305 (12.00)	300 (11.81)	16	2.000	27.500	329	

Standard Fig. No. 4A1C15

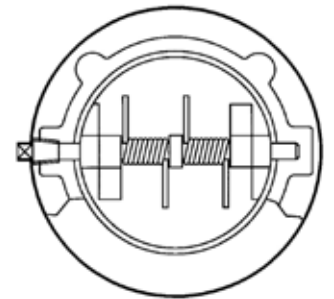

CLASS 2500 API 594	Size (In)	A	B	C	STUD SELECTION (In)			Wt. (Kg)
					No.	Dia.	Length	
3	197 (7.76)	86 (3.38)	90 (3.54)	8	1.125	10.500	14	
4	235 (9.25)	105 (4.13)	110 (4.33)	8	1.500	14.625	25	
6	318 (12.52)	159 (6.25)	166 (6.54)	12	1.375	16.750	86	
8	387 (15.24)	206 (8.11)	206 (8.11)	12	2.000	24.000	129	
10	476 (18.74)	254 (10.00)	260 (10.24)	12	2.500	30.500	228	
12	549 (21.61)	305 (12.00)	300 (11.81)	12	2.750	34.500	437	

Standard Fig. No. 4A1C25

Unit : mm (inch)

